

Footing Plan

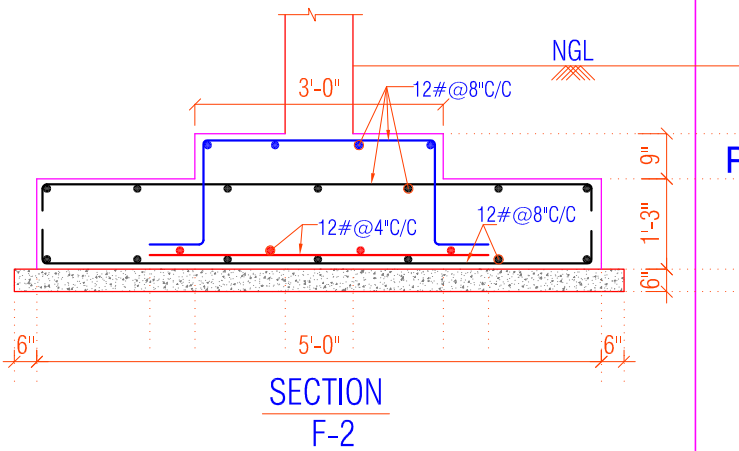

SECTION F-2

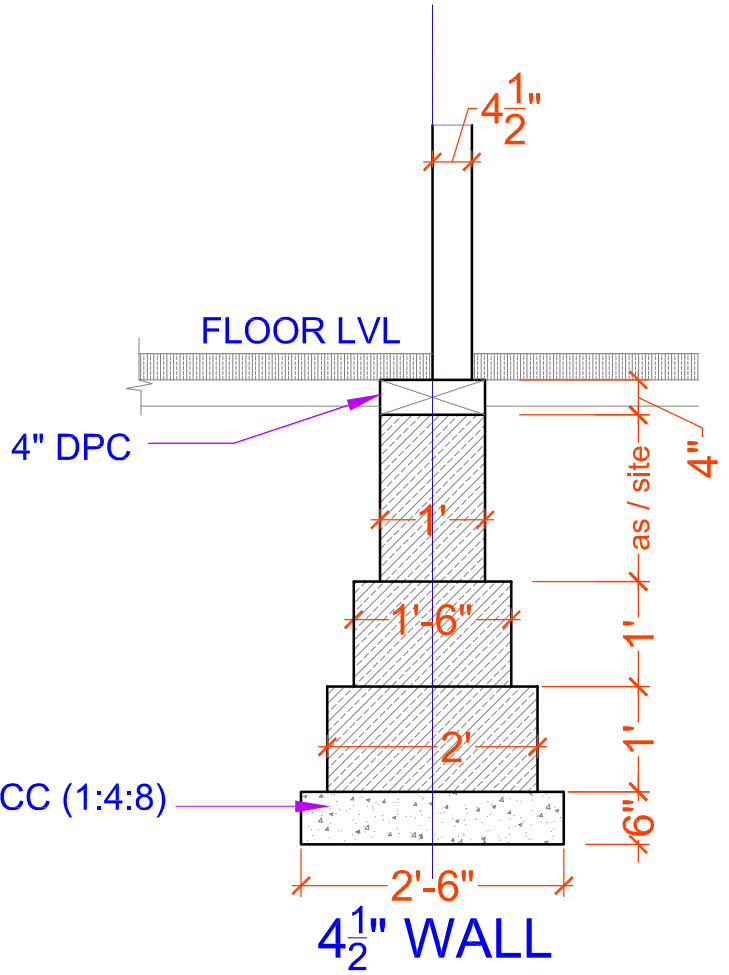

4 1/2" WALL

MIX FOR P.C.C. = 1:4:8
 MIX FOR FOOTING & SLAB = 1:2:4
 MIX FOR COLUMN = 1:1 1/2:3

Column Number	Foundation To ground Floor		Ground Floor To first floor)	
	Main Steel	Rings	Main Steel	Rings
C-1 0'-9"X1'-6"				
C-2 0'-9"X1'-6"				
C-3 9" X 9"				

8@5" C/C FOR TOP & BOTTOM (2'-6")
 # 8@8" C/C FOR CENTRE

8@5" C/C FOR TOP & BOTTOM (2'-6")
 # 8@8" C/C FOR CENTRE

SCHEDULE OF FOOTING	MARK	LENGTH (L)	WIDTH (B)	DEPTH	FOUNDATION STEEL	
				D	PARALLEL TO LONGER SIDE	PARALLEL TO SHORTER SIDE
	F-1	5'-0"	5'-0"	2'-0"	#12@8" C/C	#12@8" C/C
F-2	5'-0"	3'-3"	2'-0"	#12@8" C/C	#12@8" C/C	